

Technical Product Specifications:

FASTENERS

Approval/calculation possibilities:

- AS/NZS 32566.2
- AS/NZS 1110
- AS/NZS 2465
- AS/NZS 1252



Component List

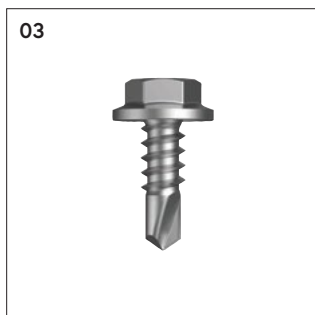

Self Drilling Screw (SDS) #08-18

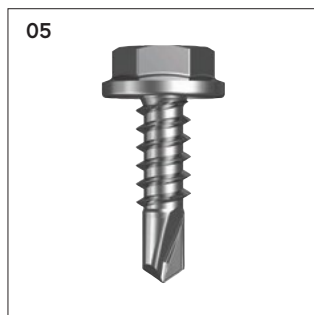

Self Drilling Screw (SDS) #10-16

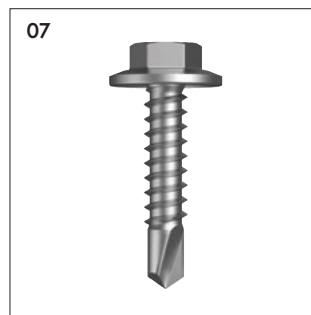

Self Drilling Screw (SDS) #12-14

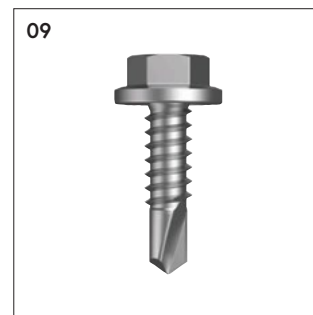

Self Drilling Screw (SDS) #14-14

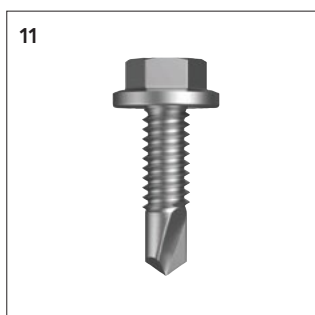

Self Drilling Screw (SDS) #14-20

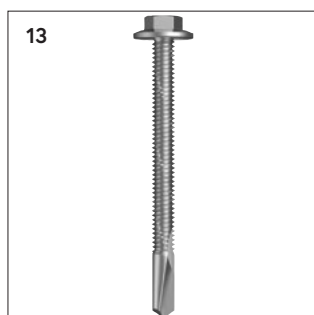

s500 Extended Drill Point

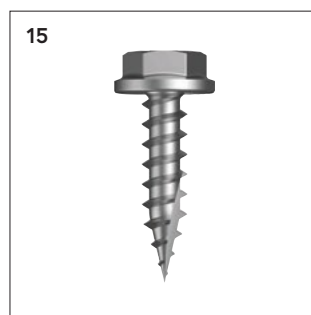

Self Drilling Timber Screw (SDS) #10-12

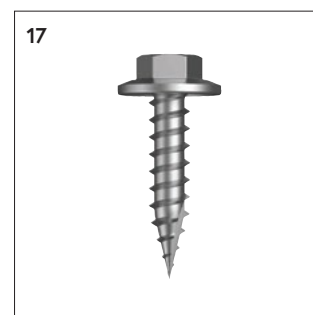

Self Drilling Timber Screw (SDS) #12-11

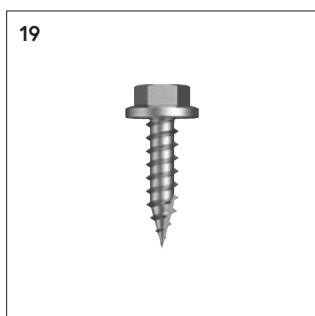

Self Drilling Timber Screw (SDS) #14-10

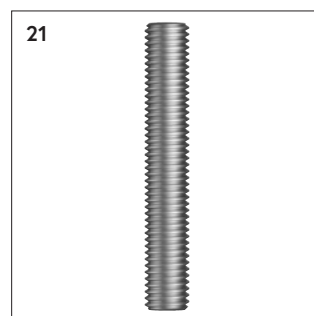

Metric Threaded Rod

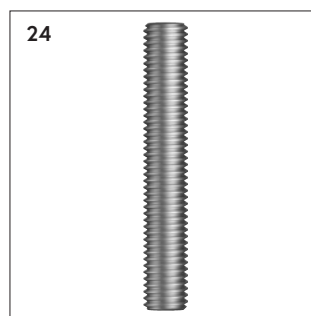

Imperial (UNC) Threaded Rod

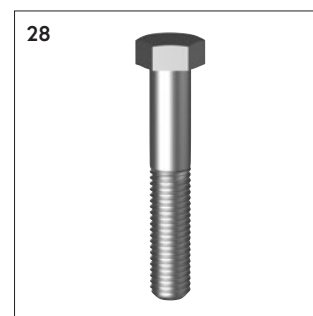

Metric Hex Bolts

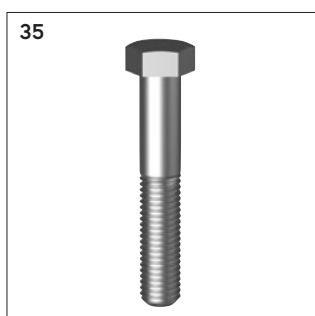

Imperial (UNC) Hex Bolts

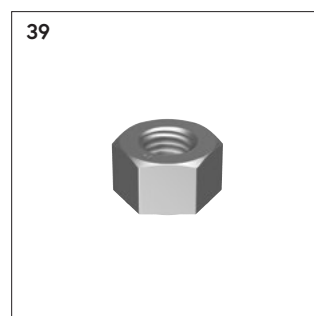

Metric Hex Nuts

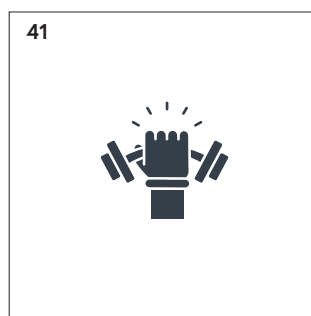

Breaking Strength Comparison

■ Metal SDS Flanged Hex Head

8 Gauge Hex Head

Self Drilling Screw (SDS) #08-18

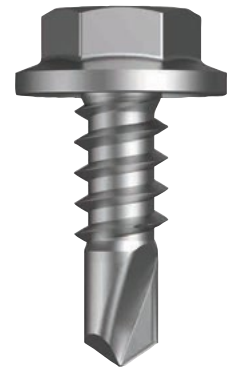

Applications

- Metal to metal fixing
- Wall cladding
- Sheds
- Fencing
- Signage
- Hinges into metal posts, gates and doors

Material	 1022	C1022 Hardened
----------	--	----------------

Finish	 CL4	Class 4
--------	---	---------

Pullout Values				
Plate (Purlin)	Metal Plate Thickness	¹ Mean Load	² Characteristic Load	³ Working Load
	(mm)	(N)	(N)	(N)
G250	0.7	950	800	300
G250	1.0	1550	1400	550
G550	1.5	3650	3150	1250
G450	2.0	4800	4150	1650
G450	2.5	6400	5450	2200

Drill Point Test							Mechanical Properties				
Part	Plate (Purlin)	Metal Plate Thickness	Load	Drill Speed	Drill Time	Drill Time	Torsional Strength	¹ Mean Tensile Strength	¹ Mean Shear Strength	² Characteristic Tensile Strength	² Characteristic Shear Strength
		(mm)	(kg)	(RPM)	(Max. individual) Seconds	(Max. average) Seconds	(Nm)	(N)	(N)	(N)	(N)
SDMHWF8-18X12G	G550	1.5	18	2200	4.5	3	4.7	8050	4850	6750	4050

Note: 1000N = 1kN

¹ Mean Load/Strength is the average ultimate strength of samples tested.

² Characteristic Load/Strength: 95% of these screws are expected to have a strength greater than the loads shown.

³ Working Load is the governing minimum allowable load obtained by comparing relevant concrete and steel working loads. Factor of Safety (FOS=2.5 for steel and FOS=3.0 for concrete) are already included.

Part	Gauge	TPI	Length	Thread Length	Drill Point Length	Head Height	Head Ø	Drive Size	Pack Qty
			L (mm)	T (mm)	DP (mm)	H (mm)	D (mm)	AF (inch)	
SDMHWF8-18X12G	8	18	12	7	5	4	10	HEX 1/4"	1000

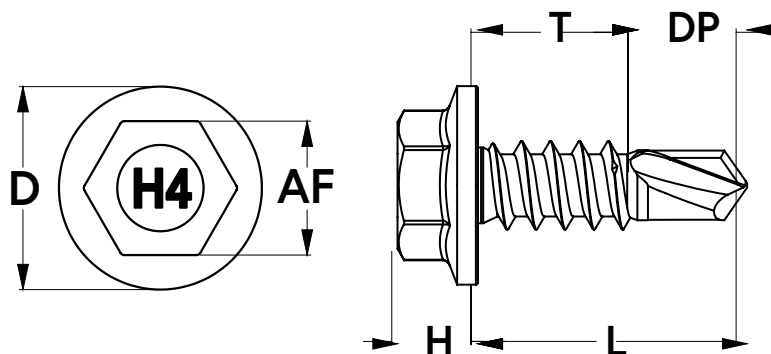

Installation

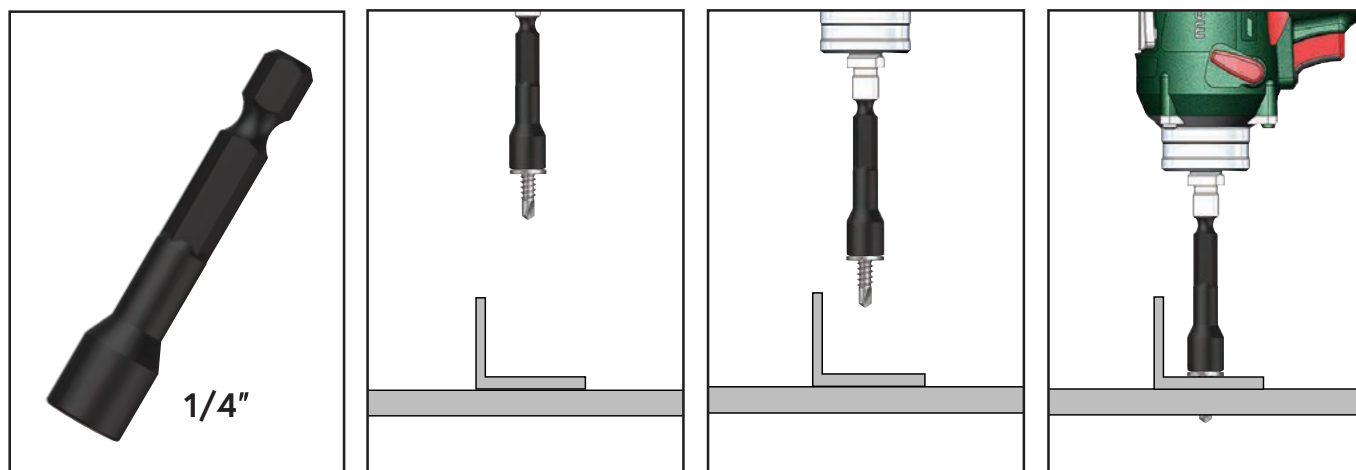

Recommended HEX 1/4 Drive Bit:

Part	Length (mm)
TBDNS1442A	42
TBDNS1465A	65

Installation Guide

1. Use a cordless screw driver set between 2,200-3,000 RPM. Fit the HEX Drive Bit over the screw and place at the fastening position.
2. Apply consistently firm pressure to the screw driver while the screw is drilling.
3. Care should be taken not to over-tighten the screw.

*Installation with impact drivers not recommended.

All values are obtained under laboratory conditions using DRiLLX product. Safety factors should be considered for design purposes. Actual pullout loads may differ slightly depending on certain properties of the base material. For more details about Hobson Engineering Testing capabilities follow the below link. <https://nata.com.au/accredited-organisation/hobson-fastener-testing-facility-18918-21151/>

■ Metal SDS Flanged Hex Head

10 Gauge Hex Head

Self Drilling Screw (SDS) #10-16

Applications

- Metal to metal fixing
- Wall cladding
- Sheds
- Fencing
- Signage
- Hinges into metal posts, gates and doors



Material		C1022 Hardened
----------	--	----------------

Finish		Class 4
--------	--	---------

Pullout Values				
Plate (Purlin)	Metal Plate Thickness	¹ Mean Load	² Characteristic Load	³ Working Load
	(mm)	(N)	(N)	(N)
G250 Purlin	0.7	950	900	350
G250 Purlin	1.1	1800	1600	650
G550 Purlin	1.5	4000	3600	1400
G450 Purlin	1.9	5200	4900	1950
G450 Purlin	2.4	7150	6300	2500

Drill Point Test						Mechanical Properties				
Part	Plate Type	Load	Drill Speed	Drill Time	Drill Time	Torsional Strength	¹ Mean Tensile Strength	¹ Mean Shear Strength	² Characteristic Tensile Strength	² Characteristic Shear Strength
	(mm)	(kg)	(RPM)	(Max. individual Seconds)	(Max. average) Seconds	(Nm)	(N)	(N)	(N)	(N)
SDMHWF10-16X16G	1.9 G450	18	2200	4	3	6.9	12700	7600	11550	6950
SDMHWF10-16X25G	1.9 G450	18	2200	4	3	6.9	12700	7600	11550	6950

Note: 1000N = 1kN

¹ Mean Load/Strength is the average ultimate strength of samples tested.

² Characteristic Load/Strength: 95% of these screws are expected to have a strength greater than the loads shown.

³ Working Load is the governing minimum allowable load obtained by comparing relevant concrete and steel working loads. Factor of Safety (FOS=2.5 for steel and FOS=3.0 for concrete) are already included.

Part	Gauge	TPI	Length	Thread Length	Drill Point Length	Head Height	Head Ø	Drive Size	Pack Qty
			L (mm)	T (mm)	DP (mm)	H (mm)	D (mm)	AF (inch)	
SDMHWF10-16X16G	10	16	16	9.8	6.2	4.5	11.0	HEX 5/16"	1000
SDMHWF10-16X25G	10	16	25	18.8	6.2	4.5	11.0	HEX 5/16"	1000

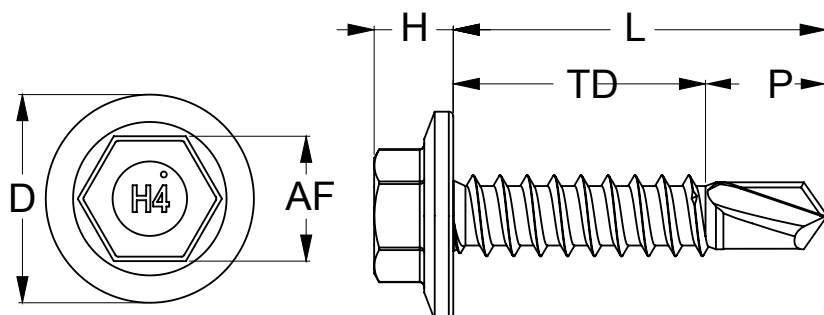

Installation

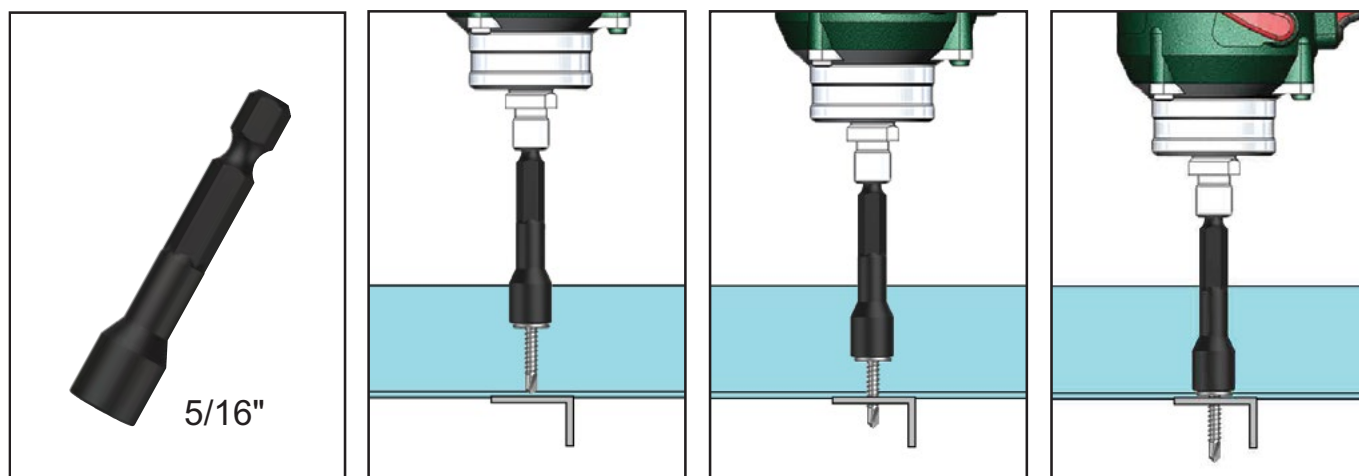

Recommended HEX 5/16 inch Drive Bit:

TXDIPNSS31045 - 45mm
 TXDIPNSS31065 - 65mm
 TXDIPNSS31100 - 100mm
 TXDIPNSS31150 - 150mm
 TXDIPNSS31200 - 200mm
 TXDIPNSS31300 - 300mm

Installation Guide

1. Use a cordless screw driver set between 2,200-3,000 RPM. Fit the HEX Drive Bit over the screw and place at the fastening position.
2. Apply consistently firm pressure to the screw driver while the screw is drilling.
3. Care should be taken not to overtighten the screw..

*Installation with impact drivers not recommended.

All values are obtained under laboratory conditions using DRiLLX product. Safety factors should be considered for design purposes. Actual pullout loads may differ slightly depending on certain properties of the base material. For more details about Hobson Engineering Testing capabilities follow the below link. <https://nata.com.au/accredited-organisation/hobson-fastener-testing-facility-18918-21151/>

■ Metal SDS Flanged Hex Head

12 Gauge Hex Head

Self Drilling Screw (SDS) #12-14

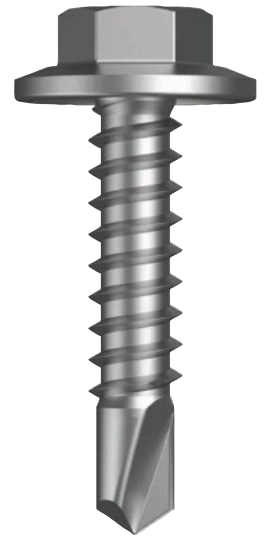

Applications

- Metal to metal fixing
- Wall cladding
- Sheds
- Fencing
- Signage
- Hinges into metal posts, gates and doors

Material	1022	C1022 Hardened
----------	------	----------------

Finish	CL4	Class 4
--------	-----	---------

Pullout Values			
Plate (Purlin)	Metal Plate Thickness	² Characteristic Strength	³ Working Load
	(mm)	(N)	(N)
G250 Purlin	1.1	1410	560
G450 Purlin	1.9	4640	1850
G450 Purlin	2.4	6210	2480
G450 Purlin	3.8	9610	3840

Drill Point Test						Mechanical Properties		
Part	Plate Type	Load	Drill Speed	Drill Time	Drill Time	Torsional Strength	² Characteristic Shear Strength	² Characteristic Tensile Strength
	(mm)	(kg)	(RPM)	(Max. individual) Seconds	(Max. average) Seconds	(Nm)	(N)	(N)
SDMHWF12-14X20G	1.9 G450	18	2200	4	3.5	10.9	8260	13780
SDMHWF12-14X25G	1.9 G450	18	2200	5.5	4	10.9	8260	13780
SDMHWF12-14X30G	1.9 G450	18	2200	5.5	4	10.9	8260	13780
SDMHWF12-14X35G	1.9 G450	18	2200	5.5	4	10.9	8260	13780
SDMHWF12-14X45G	1.9 G450	18	2200	5.5	4	10.9	8260	13780

2. Characteristic Load/Strength: 95% of these screws are expected to have a strength greater than the loads shown.

3. Working Load is the governing minimum allowable load obtained by comparing relevant concrete and steel working loads. Factor of Safety (FOS=2.5 for steel, FOS=2.5 for timber and FOS=3.0 for concrete) are already included.

Part	Gauge	TPI	Length	Thread Length	Drill Point Length	Head Height	Head Ø	Drive Size	Pack Qty
			L (mm)	T (mm)	DP (mm)	H (mm)	D (mm)	AF (inch)	
SDMHWF12-14X20G	12	14	20	13	7.4	5.5	14.4	HEX 5/16"	1000
SDMHWF12-14X25G	12	14	25	18	7.4	5.5	14.4	HEX 5/16"	1000
SDMHWF12-14X30G	12	14	30	23	7.4	5.5	14.4	HEX 5/16"	1000
SDMHWF12-14X35G	12	14	35	28	7.4	5.5	14.4	HEX 5/16"	1000
SDMHWF12-14X45G	12	14	45	38	7.4	5.5	14.4	HEX 5/16"	1000

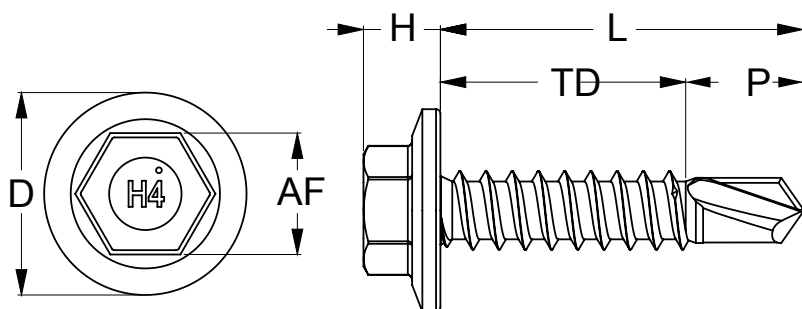

Installation

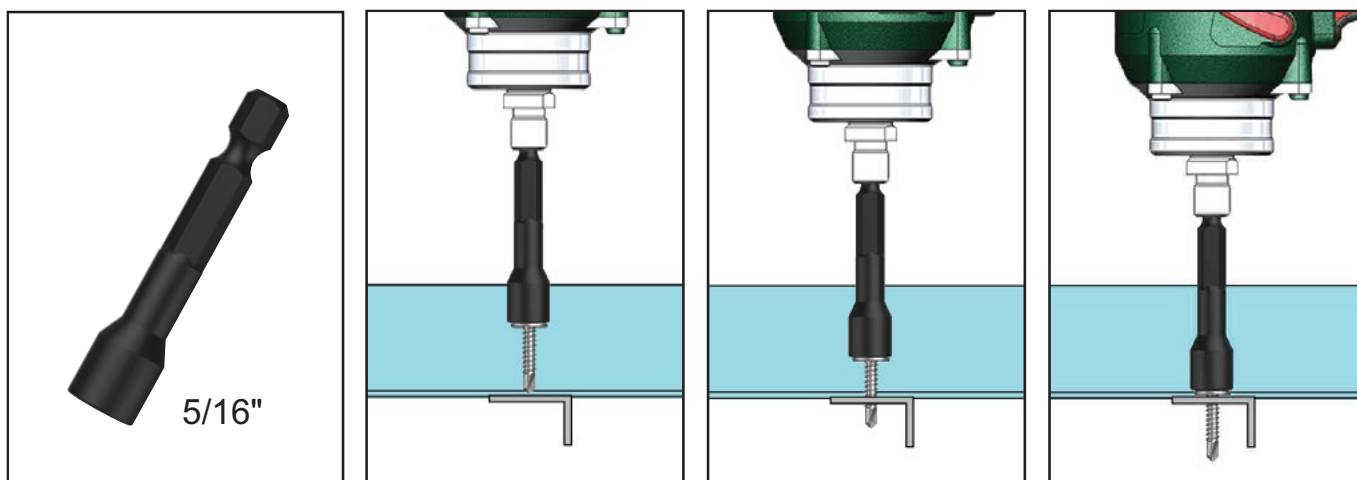

Recommended HEX 5/16 inch Drive Bit:

TBDNS51642 – 42mm
 TBDNS51665 – 65mm
 TBDNS516100 – 100mm
 TBDNS516150 – 150mm
 TBDNS516200 – 200mm
 TBDNS516300 – 300mm

Installation Guide

1. Use a cordless screw driver set between 2,200-3,000 RPM.
Fit the HEX Drive Bit over the screw and place at the fastening position.
2. Apply consistently firm pressure to the screw driver while the screw is drilling.
3. Care should be taken not to overtighten the screw..

*Installation with impact drivers not recommended.

All values are obtained under laboratory conditions using DRiLLX product. Safety factors should be considered for design purposes. Actual pullout loads may differ slightly depending on certain properties of the base material. For more details about Hobson Engineering Testing capabilities follow the below link. <https://nata.com.au/accredited-organisation/hobson-fastener-testing-facility-18918-21151/>

■ Metal SDS Flanged Hex Head

14 Gauge Hex Head

Self Drilling Screw (SDS) #14-14

Applications

- Metal to metal fixing
- Wall cladding
- Sheds
- Fencing
- Signage
- Hinges into metal posts, gates and doors



Material	1022	C1022 Hardened
----------	------	----------------

Finish	CL4	Class 4
--------	-----	---------

Pullout Values				
Plate (Purlin)	Metal Plate Thickness	¹ Mean Load	² Characteristic Load	³ Working Load
	(mm)	(N)	(N)	(N)
G250 Purlin	0.8	1100	900	350
G250 Purlin	1.2	2050	1700	650
G550 Purlin	1.6	4600	4200	1650
G450 Purlin	2.0	6000	5650	2250
G450 Purlin	2.5	7950	7300	2900
G250 Purlin	3.0	8100	7400	2950

Drill Point Test					
Part	Plate (Purlin)	Metal Plate Thickness	Load	Drill Speed	Drill Time
		(mm)	(kg)	(RPM)	(Max. average) Seconds
SDMHWF14-14X22G	G450	2.5	24	2200	5

Mechanical Properties				
Torsional Strength	¹ Mean Tensile Strength	¹ Mean Shear Strength	² Characteristic Tensile Strength	² Characteristic Shear Strength
(Nm)	(N)	(N)	(N)	(N)
16.9	22400	13450	20850	12500

Note: 1000N = 1kN

¹ Mean Load/Strength is the average ultimate strength of samples tested.

² Characteristic Load/Strength: 95% of these screws are expected to have a strength greater than the loads shown.

³ Working Load is the governing minimum allowable load obtained by comparing relevant concrete and steel working loads. Factor of Safety (FOS=2.5 for steel, FOS=2.5 for timber and FOS=3.0 for concrete) are already included.

Part	Gauge	TPI	Length	Thread Length	Drill Point Length	Head Height	Head Ø	Drive Size	Pack Qty
			L (mm)	T (mm)	DP (mm)	H (mm)	D (mm)	AF (inch)	
SDMHWF14-14X22G	14	14	22	13.5	8.5	6.2	15	HEX 3/8"	1000

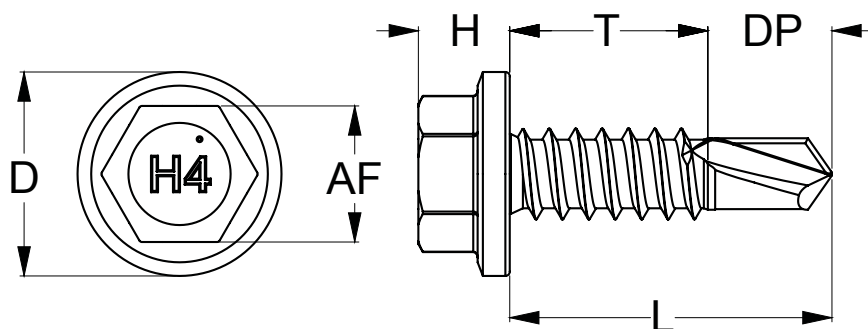

Installation

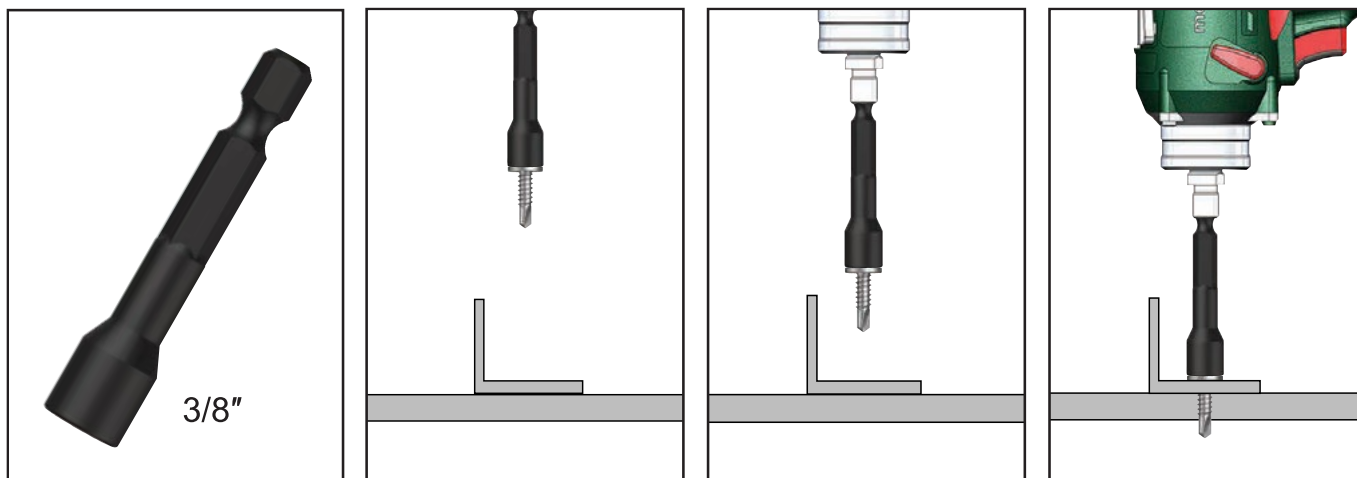

**Recommended
HEX 3/8 inch Drive Bit:**

- TBDNS3842A – 42mm
- TBDNS3865A – 65mm
- TBDNS38150A – 150mm

Installation Guide

1. Use a cordless screw driver set between 2,200-3,000 RPM.
Fit the HEX Drive Bit over the screw and place at the fastening position.
2. Apply consistently firm pressure to the screw driver while the screw is drilling.
3. Care should be taken not to overtighten the screw..

*Installation with impact drivers not recommended.

All values are obtained under laboratory conditions using DRiLLX product. Safety factors should be considered for design purposes. Actual pullout loads may differ slightly depending on certain properties of the base material. For more details about Hobson Engineering Testing capabilities follow the below link. <https://nata.com.au/accredited-organisation/hobson-fastener-testing-facility-18918-21151/>

■ Metal SDS Flanged Hex Head

14 Gauge Hex Head

Self Drilling Screw (SDS) #14-20



Applications

- Metal to metal fixing
- Wall cladding
- Sheds
- Fencing
- Signage
- Hinges into metal posts, gates and doors

Material	1022	C1022 Hardened
----------	------	----------------

Finish	CL4	Class 4
--------	-----	---------

Pullout Values				
Plate (Purlin)	Metal Plate Thickness	¹ Mean Load	² Characteristic Load	³ Working Load
	(mm)	(N)	(N)	(N)
G250 Purlin	0.8	1000	800	300
G250 Purlin	1.2	1750	1550	600
G550 Purlin	1.6	3550	2950	1200
G450 Purlin	2.0	4600	4150	1650
G450 Purlin	2.5	7900	7200	2850
G250 Purlin	3.0	6700	5700	2300

Drill Point Test					
Part	Plate (Purlin)	Metal Plate Thickness	Load	Drill Speed	Drill Time
		(mm)	(kg)	(RPM)	(Max. average) Seconds
SDMHWF14-20X22G	G450	2.5	24	2200	5
SDMHWF14-20X25G	G450	2.5	24	2200	5
SDMHWF14-20X45G	G450	2.5	24	2200	5

Mechanical Properties				
Torsional Strength	¹ Mean Tensile Strength	¹ Mean Shear Strength	² Characteristic Tensile Strength	² Characteristic Shear Strength
(Nm)	(N)	(N)	(N)	(N)
17.9	23000	13800	21500	12900
17.9	23000	13800	21500	12900
17.9	23000	13800	21500	12900

Note: 1000N = 1kN

¹ Mean Load/Strength is the average ultimate strength of samples tested.

² Characteristic Load/Strength: 95% of these screws are expected to have a strength greater than the loads shown.

³ Working Load is the governing minimum allowable load obtained by comparing relevant concrete and steel working loads. Factor of Safety (FOS=2.5 for steel, FOS=2.5 for timber and FOS=3.0 for concrete) are already included.

Part	Gauge	TPI	Length	Thread Length	Drill Point Length	Head Height	Head Ø	Drive Size	Pack Qty
			L (mm)	T (mm)	DP (mm)	H (mm)	D (mm)	AF (inch)	
SDMHWF14-20X22G	14	20	22	14	8.5	6.2	15	HEX 3/8"	1000
SDMHWF14-20X25G	14	20	25	17	8.5	6.2	15	HEX 3/8"	1000
SDMHWF14-20X45G	14	20	45	37	8.5	6.2	15	HEX 3/8"	500

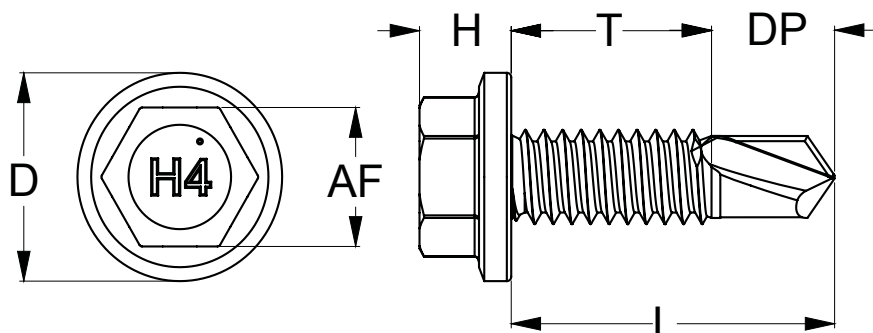

Installation

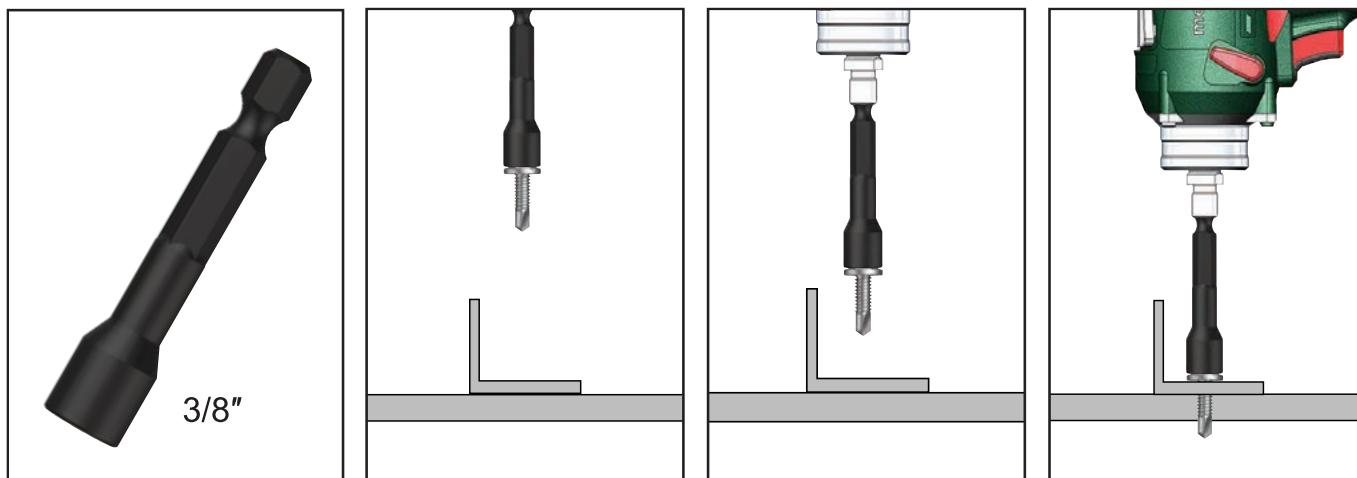

**Recommended
HEX 3/8 inch Drive Bit:**

TBDNS3842A – 42mm
TBDNS3865A – 65mm
TBDNS38150A – 150mm

Installation Guide

1. Use a cordless screw driver set between 2,200-3,000 RPM.
Fit the HEX Drive Bit over the screw and place at the fastening position.
2. Apply consistently firm pressure to the screw driver while the screw is drilling.
3. Care should be taken not to overtighten the screw..

*Installation with impact drivers not recommended.

All values are obtained under laboratory conditions using DRiLLX product. Safety factors should be considered for design purposes. Actual pullout loads may differ slightly depending on certain properties of the base material. For more details about Hobson Engineering Testing capabilities follow the below link. <https://nata.com.au/accredited-organisation/hobson-fastener-testing-facility-18918-21151/>

■ Flanged Hex Head Self Drilling Screw

s500 Extended Drill Point

- Extended drill point and fine pitch (24 TPI) thread allows self-drilling in metal up to 12mm in thickness
- No pre-drilling required
- Corrosion performance to Class 4 as per AS3566.2
- Hexagon Head Series

Applications

- Metal to metal fixing
- Thick steel purlins and hot rolled steel

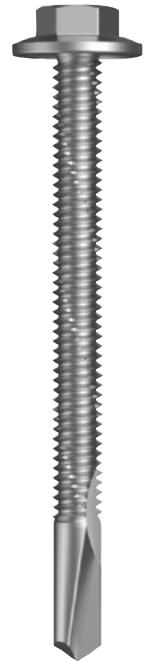

Material	1022	C1022
----------	------	-------

Used in plumbing, steel fabrication and Heating Ventilation, and Air-Conditioning (HVAC) Systems.

Finish	CL4	Class 4/AS3566.2
--------	-----	------------------

*General purpose metal to metal fixing up to 12mm total thickness.

Mechanical Properties	Gauge 12	Gauge 14
	Characteristic*	Characteristic*
Tensile Strength (N)	15,030	25,165
Shear Strength (N)	8,100	13,181
Torsional Strength (Nm)	11.3	16.9

Ultimate Pullout Strength (N)				
Base Plate	Gauge 12		Gauge 14	
	Hot Rolled Steel (HRS)	Mean^(N)	Characteristic* (N)	Mean^(N)
3.0mm HRS	6,850	4,100	8,646	5,157
6.0mm HRS	13,195	8,350	16,510	10,428
8.0mm HRS	15,030	8,350	25,165	21,968
12.0mm HRS	15,030	8,350	25,165	21,968

* Characteristic Strength - is the 5% fractile strength which has a 95% probability of being exceeded at a confidence level of 90%.
 ^Mean Ultimate Strength - is the average ultimate strength of samples tested.

Part	Gauge	TPI	Length (L)	Thread Length (TL)	Bit Driver (S)	Pack
			(mm)	(mm)	DP (mm)	Qty
SDMHWF12-24X32P5G	12	24	32	17	5/16	1000
SDMHWF12-24X50P5G	12	24	50	35	5/16	1000
SDMHWF12-24X65P5G	12	24	65	50	5/16	500
SDMHWF12-24X85P5G	12	24	85	70	5/16	500
SDMHWF14-24X38P5G	14	24	38	21	3/8	1000

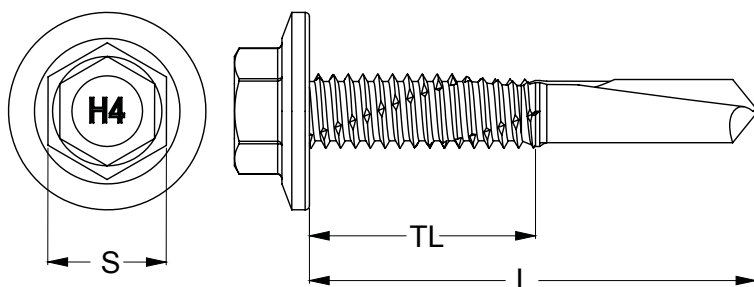

Installation

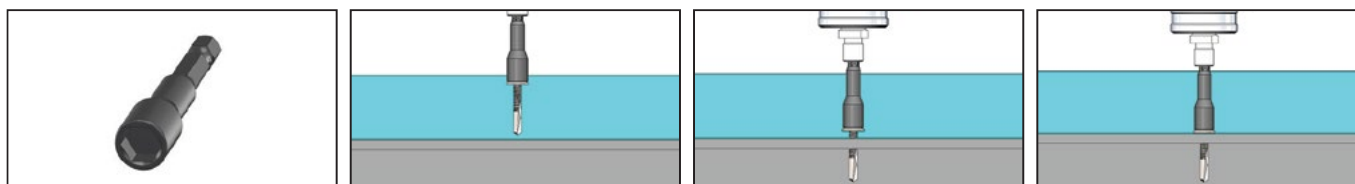

Use a 5/16 Hex Nut Setter:

Gauge 12 TBDNS51642 – 42mm
 TBDNS51665 – 65mm
 TBDNS516100 – 100mm
 TBDNS516150 – 150mm

Use a 3/8 Hex Nut Setter:

Gauge 14 TBDNS3842A – 42mm
 TBDNS3865A – 65mm

Installation Guide

1. Use a cordless screw driver set between 2,200-3,000 RPM.
Fit the Hex Nut Setter over the screw and place at the fastening position.
2. Apply consistently firm pressure to the screw driver while the screw is drilling.
3. Care should be taken not to overtighten the screw..

All values are obtained under laboratory conditions using DRiLLX product. Safety factors should be considered for design purposes. Actual pullout loads may differ slightly depending on certain properties of the base material. For more details about Hobson Engineering Testing capabilities follow the below link. <https://nata.com.au/accredited-organisation/hobson-fastener-testing-facility-18918-21151/>

■ Timber Type 17 Flanged Hex Head

10 Gauge Flanged Hex Head

Self Drilling Timber Screw (SDS) #10-12

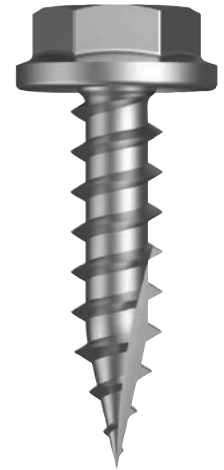

Applications

- For fixing timber or thin metal to timber
- Timber brackets
- Cladding/panels to timber battens

Material	 1022	C1022 Hardened
Finish	 CL4	Class 4

Pullout Values				
Plate Material	Timber Embedment	¹ Mean Load	² Characteristic Load	³ Working Load
	(mm)	(N)	(N)	(N)
F7 and GS8 Pine	35	5400	3750	1500
F27 Hardwood	35	7850	6900	2750

Mechanical Properties					
Part	Torsional Strength	¹ Mean Tensile Strength	¹ Mean Shear Strength	² Characteristic Tensile Strength	² Characteristic Shear Strength
	(Nm)	(N)	(N)	(N)	(N)
T1710-12X20HWFG	5.4	10750	6450	9350	5600
T1710-12X25HWFG	5.4	10750	6450	9350	5600

Note: 1000N = 1kN

¹ Mean Load/Strength is the average ultimate strength of samples tested.

² Characteristic Load/Strength: 95% of these screws are expected to have a strength greater than the loads shown.

³ Working Load is the governing minimum allowable load obtained by comparing relevant concrete and steel working loads. Factor of Safety (FOS=2.5 for steel, FOS=2.5 for timber and FOS=3.0 for concrete) are already included.

Part	Gauge	TPI	Length	Head Height	Head Ø	Drive Size
			L (mm)	H (mm)	D (mm)	AF (inch)
T1710-12X20HWFG	10	12	20	4.5	11.0	HEX 5/16"
T1710-12X30HWFG	10	12	30	4.5	11.0	HEX 5/16"

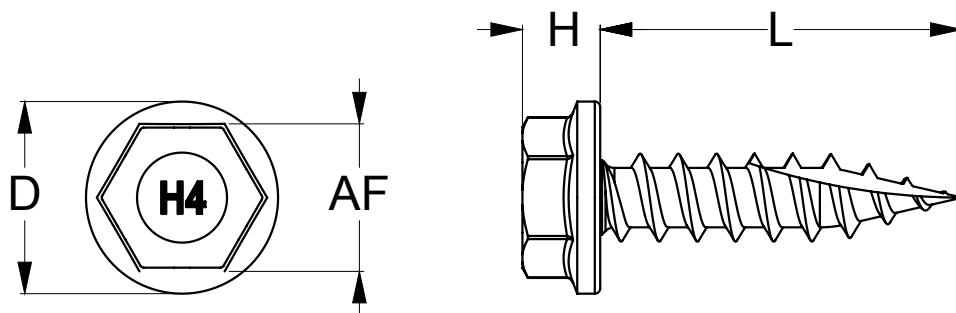

Installation

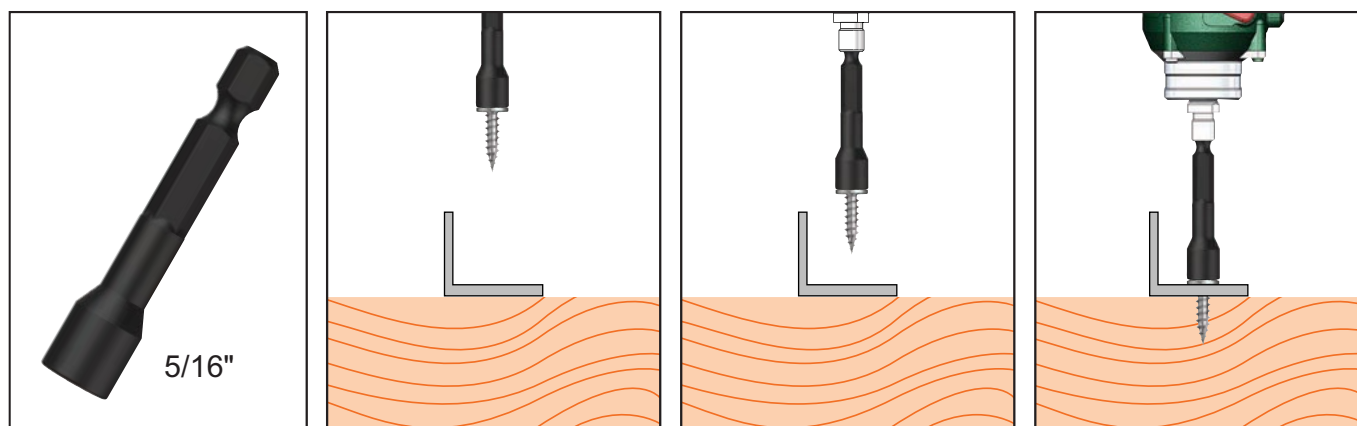

Recommended HEX 5/16 inch Drive Bit:

Part	Length (mm)
TBDNS51642	42
TBDNS51665	65

Installation Guide

1. Use a cordless screw driver set at max 1,500 RPM. Fit the HEX Drive Bit over the screw and place at the fastening position.
2. Apply consistently firm pressure to the screw driver while the screw is drilling.
3. Care should be taken not to over-tighten the screw.

*Installation with impact drivers not recommended.

All values are obtained under laboratory conditions using DRiLLX product. Safety factors should be considered for design purposes. Actual pullout loads may differ slightly depending on certain properties of the base material. For more details about Hobson Engineering Testing capabilities follow the below link. <https://nata.com.au/accredited-organisation/hobson-fastener-testing-facility-18918-21151/>

■ Timber Type 17 Flanged Hex Head



12 Gauge Flanged Hex Head

Self Drilling Timber Screw (SDS) #12-11



Applications

- For fixing timber or thin metal to timber
- Timber brackets
- Cladding/panels to timber battens

Material	 1022	C1022 Hardened
Finish	 CL4	Class 4

Pullout Values				
Plate Material	Timber Embedment	¹ Mean Load	² Characteristic Load	³ Working Load
	(mm)	(N)	(N)	(N)
F7 and GS8 Pine	35	5800	5300	2100
F27 Hardwood	35	7950	7450	3000

Mechanical Properties					
Part	Torsional Strength	¹ Mean Tensile Strength	¹ Mean Shear Strength	² Characteristic Tensile Strength	² Characteristic Shear Strength
	(Nm)	(N)	(N)	(N)	(N)
T1712-11X25HWFG	9.4	16400	9850	15100	9050
T1712-11X30HWFG	9.4	16400	9850	15100	9050
T1712-11X35HWFG	9.4	16400	9850	15100	9050
T1712-11X40HWFG	9.4	16400	9850	15100	9050

Note: 1000N = 1kN

¹ Mean Load/Strength is the average ultimate strength of samples tested.

² Characteristic Load/Strength: 95% of these screws are expected to have a strength greater than the loads shown.

³ Working Load is the governing minimum allowable load obtained by comparing relevant concrete and steel working loads. Factor of Safety (FOS=2.5 for steel, FOS=2.5 for timber and FOS=3.0 for concrete) are already included.

Part	Gauge	TPI	Length	Head Height	Head Ø	Drive Size
			L (mm)	H (mm)	D (mm)	AF (inch)
T1712-11X25HWFG	12	11	25	5.5	14.5	HEX 5/16"
T1712-11X30HWFG	12	11	30	5.5	14.5	HEX 5/16"
T1712-11X35HWFG	12	11	35	5.5	14.5	HEX 5/16"
T1712-11X40HWFG	12	11	40	5.5	14.5	HEX 5/16"

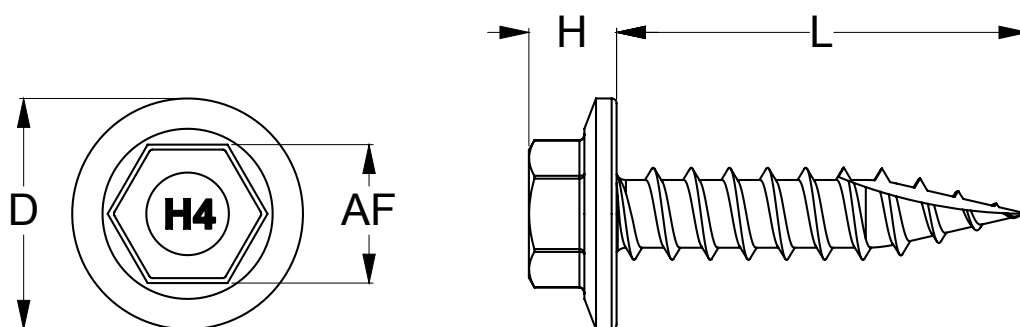

Installation

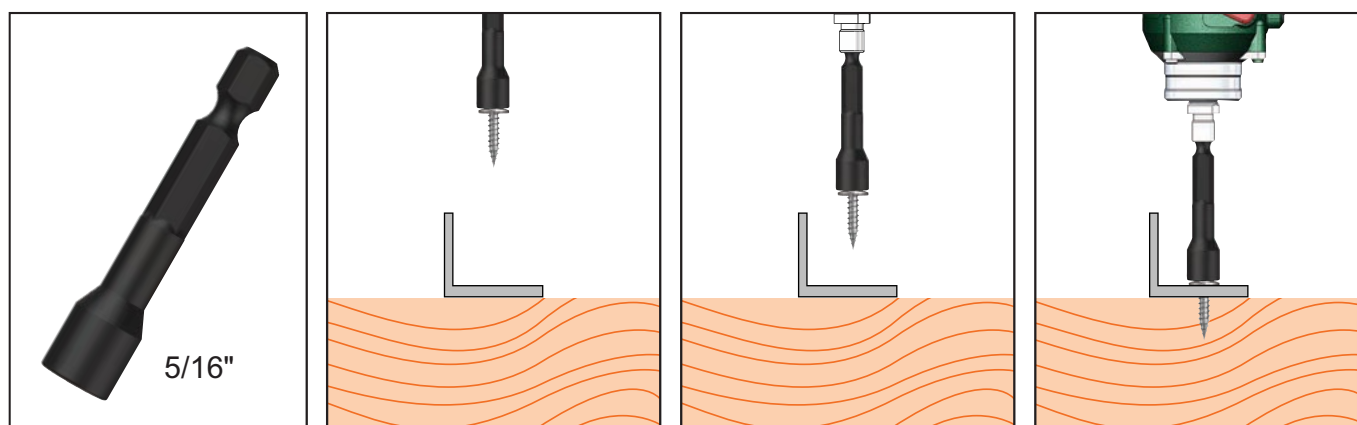

Recommended HEX 5/16 inch Drive Bit:

Part	Length (mm)
TBDNS51642	42
TBDNS51665	65

Installation Guide

1. Use a cordless screw driver set at max 1,500 RPM. Fit the HEX Drive Bit over the screw and place at the fastening position.
2. Apply consistently firm pressure to the screw driver while the screw is drilling.
3. Care should be taken not to over-tighten the screw.

*Installation with impact drivers not recommended.

All values are obtained under laboratory conditions using DRiLLX product. Safety factors should be considered for design purposes. Actual pullout loads may differ slightly depending on certain properties of the base material. For more details about Hobson Engineering Testing capabilities follow the below link. <https://nata.com.au/accredited-organisation/hobson-fastener-testing-facility-18918-21151/>

■ Timber Type 17 Flanged Hex Head

14 Gauge Flanged Hex Head

Self Drilling Timber Screw (SDS) #14-10

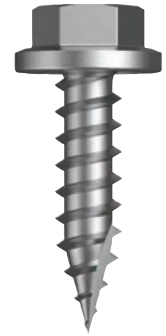

Applications

- For fixing timber or thin metal to timber
- Timber brackets
- Cladding/panels to timber battens

Material	 1022	C1022 Hardened
Finish	 CL4	Class 4

Pullout Values				
Plate Material	Timber Embedment	¹ Mean Load	² Characteristic Load	³ Working Load
	(mm)	(N)	(N)	(N)
F7 and GS8 Pine	35	6450	4350	1750
F27 Hardwood	35	8150	7350	2950

Mechanical Properties					
Part	Torsional Strength	¹ Mean Tensile Strength	¹ Mean Shear Strength	² Characteristic Tensile Strength	² Characteristic Shear Strength
	(Nm)	(N)	(N)	(N)	(N)
T1714-10X25HWFG	14.1	21950	13150	19650	11800
T1714-10X30HWFG	14.1	21950	13150	19650	11800
T1714-10X40HWFG	14.1	21950	13150	19650	11800

Note: 1000N = 1kN

¹ Mean Load/Strength is the average ultimate strength of samples tested.

² Characteristic Load/Strength: 95% of these screws are expected to have a strength greater than the loads shown.

³ Working Load is the governing minimum allowable load obtained by comparing relevant concrete and steel working loads. Factor of Safety (FOS=2.5 for steel, FOS=2.5 for timber and FOS=3.0 for concrete) are already included.

Part	Gauge	TPI	Length	Head Height	Head Ø	Drive Size
			L (mm)	H (mm)	D (mm)	AF (inch)
T1714-10X25HWFG	14	10	25	6	14.5	HEX 3/8"
T1714-10X30HWFG	14	10	30	6	14.5	HEX 3/8"
T1714-10X40HWFG	14	10	40	6	14.5	HEX 3/8"

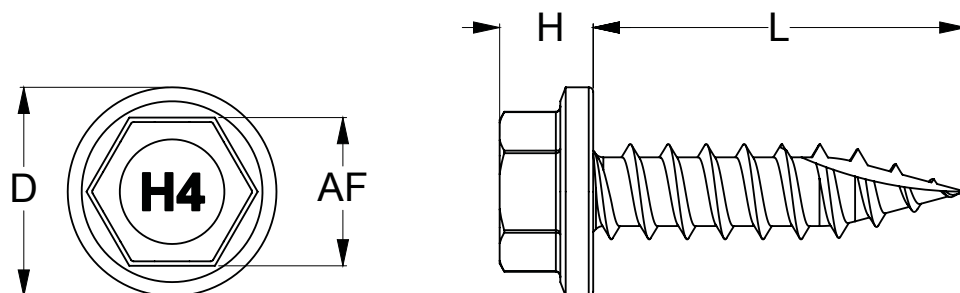

Installation

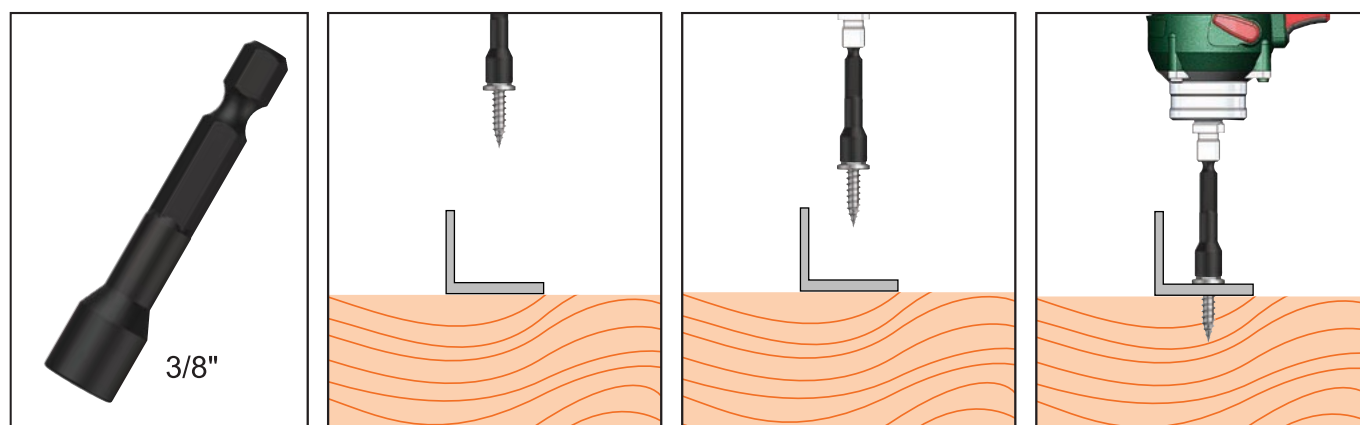

Recommended HEX 3/8 inch Drive Bit:

Part	Length (mm)
TBDNS3842A	42
TBDNS3865A	65
TBDNS38150A	150

Installation Guide

1. Use a cordless screw driver set at max 1,500 RPM. Fit the HEX Drive Bit over the screw and place at the fastening position.
2. Apply consistently firm pressure to the screw driver while the screw is drilling.
3. Care should be taken not to over-tighten the screw.

*Installation with impact drivers not recommended.

All values are obtained under laboratory conditions using DRiLLX product. Safety factors should be considered for design purposes. Actual pullout loads may differ slightly depending on certain properties of the base material. For more details about Hobson Engineering Testing capabilities follow the below link. <https://nata.com.au/accredited-organisation/hobson-fastener-testing-facility-18918-21151/>

■ Metric Threaded Rod

CLASS 4.6 THREADED ROD AS1252 / HSFG									
Size	Pitch (mm)	Stress Area (mm ²)	Core Area (mm ²)	Tensile Strength (kN)	Proof Strength (kN)	Shear Strength (kN)	Recommended Tightening Torque		
							Plain (Nm)	Zinc (Nm)	HDG (Nm)
M3	0.50	5.0	4.5	2.0	1.1	1.1	0.4	0.3	0.9
M4	0.70	8.8	7.8	3.5	2.0	1.9	1.0	0.7	2.2
M5	0.80	14.2	12.7	5.7	3.2	3.0	2.1	1.5	4.4
M6	1.00	20.1	17.9	8.0	4.5	4.3	3.5	2.5	7.4
M8	1.25	36.6	32.8	14.6	8.2	7.9	8.6	6.0	18.0
M10	1.50	58.0	52.3	23.2	13.1	12.6	17.0	11.9	35.6
M12	1.75	84.3	76.2	33.7	19.0	18.3	29.6	20.7	62.1
M14	2.00	115.0	104.7	46.0	25.9	25.1	47.1	33.0	98.9
M16	2.00	157.0	144.0	62.8	35.3	34.6	73.5	51.4	154.3
M18	2.50	192.0	175.0	76.8	43.2	42.0	101.1	70.8	212.3
M20	2.50	245.0	225.0	98.0	55.1	54.0	143.3	100.3	301.0
M22	2.50	303.0	281.0	121.2	68.2	67.4	195.0	136.5	409.5
M24	3.00	353.0	324.0	141.2	79.4	77.8	247.8	173.5	520.4
M27	3.00	459.0	427.0	183.6	103.3	102.5	362.5	253.7	761.2
M30	3.50	561.0	519.0	224.4	126.2	124.6	492.3	344.6	1033.8
M33	3.50	694.0	647.0	277.6	156.2	155.3	669.9	468.9	1406.8
M36	4.00	817.0	759.0	326.8	183.8	182.2	860.3	602.2	1806.6
M39	4.00	976.0	912.0	390.4	219.6	218.9	1113.4	779.4	2338.1
M42	4.50	1120.0	1050.0	448.0	252.0	252.0	1375.9	963.1	2889.4
M48	5.00	1470.0	1380.0	588.0	330.8	331.2	2063.9	1444.7	4334.1
M56	5.50	2030.0	1910.0	812.0	456.8	458.4	3325.1	2327.6	6982.8
M64	6.00	2680.0	2520.0	1072.0	603.0	604.8	5017.0	3511.9	10535.6



Note: The tightening torque values given in the above table serve only as a guide. A k factor of 0.2 has been used which assumes threads are plain finish, burr free with a light oil coating. It should be noted that these figures are based on the first tightening of single assemblies in isolation.

■ Metric Threaded Rod

CLASS 8.8 THREADED ROD AS1252 / HSG									
Size	Pitch (mm)	Stress Area (mm ²)	Core Area (mm ²)	Tensile Strength (kN)	Proof Strength (kN)	Shear Strength (kN)	Recommended Tightening Torque		
							Plain (Nm)	Zinc (Nm)	HDG (Nm)
M6	1.00	20.1	17.9	16.1	11.7	8.6	9.1	6.4	19.1
M8	1.25	36.6	32.8	29.3	21.2	15.7	22.1	15.5	46.4
M10	1.50	58.0	52.3	46.4	33.6	25.1	43.7	30.6	91.8
M12	1.75	84.3	76.2	67.4	48.9	36.6	76.3	53.4	160.2
M14	2.00	115.0	104.7	92.0	66.7	50.3	121.4	85.0	254.9
M16	2.00	157.0	144.0	125.6	91.1	69.1	189.4	132.6	397.8
M18	2.50	192.0	175.0	159.4	115.2	84.0	269.6	188.7	566.1
M20	2.50	245.0	225.0	203.3	147.0	108.0	382.0	268.0	803.0
M22	2.50	303.0	281.0	251.5	181.8	134.9	520.0	364.0	1092.0
M24	3.00	353.0	324.0	293.0	211.8	155.5	661.0	463.0	1388.0
M27	3.00	459.0	427.0	381.0	275.4	205.0	967.0	677.0	2030.0
M30	3.50	561.0	519.0	465.6	336.6	249.1	1313.0	919.0	2757.0
M33	3.50	694.0	647.0	576.0	416.4	310.6	1786.0	1250.0	3751.0
M36	4.00	817.0	759.0	678.1	490.2	364.3	2294.0	1606.0	4818.0
M39	4.00	976.0	912.0	810.1	585.6	437.8	2969.0	2078.0	6235.0
M42	4.50	1120.0	1050.0	929.6	672.0	504.0	3670.0	2568.0	7705.0
M48	5.00	1470.0	1380.0	1220.1	882.0	662.4	5504.0	3853.0	11558.0
M56	5.50	2030.0	1910.0	1684.9	1218.0	916.8	8867.0	6207.0	18621.0
M64	6.00	2680.0	2520.0	2224.4	1608.0	1209.6	13379.0	9365.0	28095.0



Note: The tightening torque values given in the above table serve only as a guide. A k factor of 0.2 has been used which assumes threads are plain finish, burr free with a light oil coating. It should be noted that these figures are based on the first tightening of single assemblies in isolation.

■ Metric Threaded Rod

CLASS 10.9 THREADED ROD AS1252 / HSFG									
Size	Pitch (mm)	Stress Area (mm ²)	Core Area (mm ²)	Tensile Strength (kN)	Proof Strength (kN)	Shear Strength (kN)	Recommended Tightening Torque		
							Plain (Nm)	Zinc (Nm)	HDG (Nm)
M6	1.00	20.1	17.9	20.9	16.7	8.6	13.0	9.1	27.3
M8	1.25	36.6	32.8	38.1	30.4	15.7	31.6	22.1	66.3
M10	1.50	58.0	52.3	60.3	48.1	25.1	62.6	43.8	131.4
M12	1.75	84.3	76.2	87.7	70.0	36.6	109.2	76.4	229.2
M14	2.00	115.0	104.7	119.6	95.5	50.3	173.7	121.6	364.8
M16	2.00	157.0	144.0	163.3	130.3	69.1	271.0	189.7	569.2
M18	2.50	192.0	175.0	199.7	159.4	84.0	372.9	261.0	783.1
M20	2.50	245.0	225.0	254.8	203.3	108.0	528.7	370.1	1110.3
M22	2.50	303.0	281.0	315.1	251.5	134.9	719.3	503.5	1510.4
M24	3.00	353.0	324.0	367.1	293.0	155.5	914.1	639.9	1919.7
M27	3.00	459.0	427.0	477.4	381.0	205.0	1337.2	936.0	2808.1
M30	3.50	561.0	519.0	583.4	465.6	249.1	1816.0	1271.2	3813.5
M33	3.50	694.0	647.0	721.8	576.0	310.6	2471.1	1729.8	5189.4
M36	4.00	817.0	759.0	849.7	678.1	364.3	3173.6	2221.5	6664.5
M39	4.00	976.0	912.0	1015.0	810.1	437.8	4107.1	2875.0	8624.9
M42	4.50	1120.0	1050.0	1164.8	929.6	504.0	5075.6	3552.9	10658.8
M48	5.00	1470.0	1380.0	1528.8	1220.1	662.4	7613.4	5329.4	15988.2
M56	5.50	2030.0	1910.0	2111.2	1684.9	916.8	12266.1	8586.3	25758.8
M64	6.00	2680.0	2520.0	2787.2	2224.4	1209.6	18507.0	12954.9	38864.7



Note: The tightening torque values given in the above table serve only as a guide. A k factor of 0.2 has been used which assumes threads are plain finish, burr free with a light oil coating. It should be noted that these figures are based on the first tightening of single assemblies in isolation.

■ Imperial (UNC) Threaded Rod

UNC THREADED ROD - MINIMUM STRESS UNDER PROOF LOAD (lbf/in ²)					
Nominal Size	TPI	Stress Area in ²	Grade 2	Grade 5	Grade 8
1/4"	20	0.0318	55,000	85,000	120,000
5/16"	18	0.0524	55,000	85,000	120,000
3/8"	16	0.0775	55,000	85,000	120,000
7/16"	14	0.1063	55,000	85,000	120,000
1/2"	13	0.1419	55,000	85,000	120,000
9/16"	12	0.182	55,000	85,000	120,000
5/8"	11	0.226	55,000	85,000	120,000
3/4"	10	0.334	55,000	85,000	120,000
7/8"	9	0.462	33,000	85,000	120,000
1"	8	0.606	33,000	85,000	120,000
1 1/8"	7	0.763	33,000	74,000	120,000
1 1/4"	7	0.969	33,000	74,000	120,000
1 3/8"	6	1.155	33,000	74,000	120,000
1 1/2"	6	1.405	33,000	74,000	120,000
1 3/4**	5	1.9	33,000	74,000	120,000
2**	4.5	2.5	33,000	74,000	120,000
2 1/4**	4.5	3.25	33,000	74,000	120,000



*Extrapolated

■ Imperial (UNC) Threaded Rod

UNC THREADED ROD - MINIMUM TENSILE STRESS (lbf/in ²)					
Nominal Size	TPI	Stress Area in ²	Grade 2	Grade 5	Grade 8
1/4"	20	0.0318	74,000	120,000	150,000
5/16"	18	0.0524	74,000	120,000	150,000
3/8"	16	0.0775	74,000	120,000	150,000
7/16"	14	0.1063	74,000	120,000	150,000
1/2"	13	0.1419	74,000	120,000	150,000
9/16"	12	0.182	74,000	120,000	150,000
5/8"	11	0.226	74,000	120,000	150,000
3/4"	10	0.334	74,000	120,000	150,000
7/8"	9	0.462	60,000	120,000	150,000
1"	8	0.606	60,000	120,000	150,000
1 1/8"	7	0.763	60,000	105,000	150,000
1 1/4"	7	0.969	60,000	105,000	150,000
1 3/8"	6	1.155	60,000	105,000	150,000
1 1/2"	6	1.405	60,000	105,000	150,000
1 3/4**	5	1.9	60,000	105,000	150,000
2**	4.5	2.5	60,000	105,000	150,000
2 1/4**	4.5	3.25	60,000	105,000	150,000



*Extrapolated

Imperial (UNC) Threaded Rod

UNC THREADED ROD - MINIMUM PROOF LOAD (lbf)					
Nominal Size	TPI	Stress Area in ²	Grade 2	Grade 5	Grade 8
1/4"	20	0.0318	1,749	2,703	3,816
5/16"	18	0.0524	2,882	4,454	6,288
3/8"	16	0.0775	4,263	6,588	9,300
7/16"	14	0.1063	5,847	9,036	12,756
1/2"	13	0.1419	7,805	12,062	17,028
9/16"	12	0.182	10,010	15,470	21,840
5/8"	11	0.226	12,430	19,210	27,120
3/4"	10	0.334	18,370	28,390	40,080
7/8"	9	0.462	15,246	39,270	55,440
1"	8	0.606	19,998	51,510	72,720
1 1/8"	7	0.763	25,179	56,462	91,560
1 1/4"	7	0.969	31,977	71,706	116,280
1 3/8"	6	1.155	38,115	85,470	138,600
1 1/2"	6	1.405	46,365	103,970	168,600
1 3/4**	5	1.9	62,700	140,600	228,000
2**	4.5	2.5	82,500	185,000	300,000
2 1/4**	4.5	3.25	107,250	240,500	390,000



*Extrapolated

Imperial (UNC) Threaded Rod

UNC THREADED ROD - MINIMUM ULTIMATE TENSILE LOAD (lbf)					
Nominal Size	TPI	Stress Area in ²	Grade 2	Grade 5	Grade 8
1/4"	20	0.0318	2,353	3,816	4,770
5/16"	18	0.0524	3,878	6,288	7,860
3/8"	16	0.0775	5,735	9,300	11,625
7/16"	14	0.1063	7,866	12,756	15,945
1/2"	13	0.1419	10,501	17,028	21,285
9/16"	12	0.182	13,468	21,840	27,300
5/8"	11	0.226	16,724	27,120	33,900
3/4"	10	0.334	24,716	40,080	50,100
7/8"	9	0.462	27,720	55,440	69,300
1"	8	0.606	36,360	72,720	90,900
1 1/8"	7	0.763	45,780	80,115	114,450
1 1/4"	7	0.969	58,140	101,745	145,350
1 3/8"	6	1.155	69,300	121,275	173,250
1 1/2"	6	1.405	84,300	147,525	210,750
1 3/4**	5	1.9	114,000	199,500	285,000
2**	4.5	2.5	150,000	262,500	375,000
2 1/4**	4.5	3.25	195,000	341,250	487,500



*Extrapolated

■ Metric Hex Bolts

HEX BOLTS - RECOMMENDED TIGHTENING TORQUE									
Class 4.6									
Size	Pitch (mm)	Stress Area (mm ²)	Core Area (mm ²)	Tensile Strength (kN)	Proof Strength (kN)	Shear Strength (kN)	Recommended Tightening Torque		
							Plain (Nm)	Zinc (Nm)	HDG (Nm)
M3	0.50	5.0	4.5	2.0	1.1	1.1	0.4	0.3	0.9
M4	0.70	8.8	7.8	3.5	2.0	1.9	1.0	0.7	2.2
M5	0.80	14.2	12.7	5.7	3.2	3.0	2.1	1.5	4.4
M6	1.00	20.1	17.9	8.0	4.5	4.3	3.5	2.5	7.4
M8	1.25	36.6	32.8	14.6	8.2	7.9	8.6	6.0	18.0
M10	1.50	58.0	52.3	23.2	13.1	12.6	17.0	11.9	35.6
M12	1.75	84.3	76.2	33.7	19.0	18.3	29.6	20.7	62.1
M14	2.00	115.0	104.7	46.0	25.9	25.1	47.1	33.0	98.9
M16	2.00	157.0	144.0	62.8	35.3	34.6	73.5	51.4	154.3
M18	2.50	192.0	175.0	76.8	43.2	42.0	101.1	70.8	212.3
M20	2.50	245.0	225.0	98.0	55.1	54.0	143.3	100.3	301.0
M22	2.50	303.0	281.0	121.2	68.2	67.4	195.0	136.5	409.5
M24	3.00	353.0	324.0	141.2	79.4	77.8	247.8	173.5	520.4
M27	3.00	459.0	427.0	183.6	103.3	102.5	362.5	253.7	761.2
M30	3.50	561.0	519.0	224.4	126.2	124.6	492.3	344.6	1033.8
M33	3.50	694.0	647.0	277.6	156.2	155.3	669.9	468.9	1406.8
M36	4.00	817.0	759.0	326.8	183.8	182.2	860.3	602.2	1806.6
M39	4.00	976.0	912.0	390.4	219.6	218.9	1113.4	779.4	2338.1
M42	4.50	1120.0	1050.0	448.0	252.0	252.0	1375.9	963.1	2889.4
M48	5.00	1470.0	1380.0	588.0	330.8	331.2	2063.9	1444.7	4334.1
M56	5.50	2030.0	1910.0	812.0	456.8	458.4	3325.1	2327.6	6982.8
M64	6.00	2680.0	2520.0	1072.0	603.0	604.8	5017.0	3511.9	10535.6



Note: The tightening torque values given in the above table serve only as a guide. A k factor of 0.2 has been used which assumes threads are plain finish, burr free with a light oil coating. It should be noted that these figures are based on the first tightening of single assemblies in isolation.

■ Metric Hex Bolts

HEX BOLTS - RECOMMENDED TIGHTENING TORQUE									
Class 8.8									
Size	Pitch (mm)	Stress Area (mm ²)	Core Area (mm ²)	Tensile Strength (kN)	Proof Strength (kN)	Shear Strength (kN)	Recommended Tightening Torque		
							Plain (Nm)	Zinc (Nm)	HDG (Nm)
M6	1.00	20.1	17.9	16.1	11.7	8.6	9.1	6.4	19.1
M8	1.25	36.6	32.8	29.3	21.2	15.7	22.1	15.5	46.4
M10	1.50	58.0	52.3	46.4	33.6	25.1	43.7	30.6	91.8
M12	1.75	84.3	76.2	67.4	48.9	36.6	76.3	53.4	160.2
M14	2.00	115.0	104.7	92.0	66.7	50.3	121.4	85.0	254.9
M16	2.00	157.0	144.0	125.6	91.1	69.1	189.4	132.6	397.8
M18	2.50	192.0	175.0	159.4	115.2	84.0	269.6	188.7	566.1
M20	2.50	245.0	225.0	203.3	147.0	108.0	382.0	268.0	803.0
M22	2.50	303.0	281.0	251.5	181.8	134.9	520.0	364.0	1092.0
M24	3.00	353.0	324.0	293.0	211.8	155.5	661.0	463.0	1388.0
M27	3.00	459.0	427.0	381.0	275.4	205.0	967.0	677.0	2030.0
M30	3.50	561.0	519.0	465.6	336.6	249.1	1313.0	919.0	2757.0
M33	3.50	694.0	647.0	576.0	416.4	310.6	1786.0	1250.0	3751.0
M36	4.00	817.0	759.0	678.1	490.2	364.3	2294.0	1606.0	4818.0
M39	4.00	976.0	912.0	810.1	585.6	437.8	2969.0	2078.0	6235.0
M42	4.50	1120.0	1050.0	929.6	672.0	504.0	3670.0	2568.0	7705.0
M48	5.00	1470.0	1380.0	1220.1	882.0	662.4	5504.0	3853.0	11558.0
M56	5.50	2030.0	1910.0	1684.9	1218.0	916.8	8867.0	6207.0	18621.0
M64	6.00	2680.0	2520.0	2224.4	1608.0	1209.6	13379.0	9365.0	28095.0

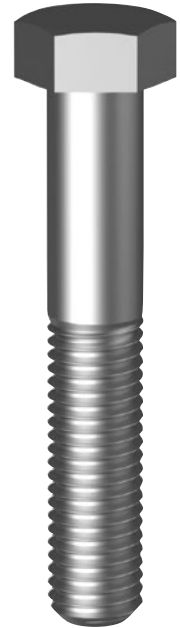

***Not to be used for structural fasteners or structural applications.**

Note: The tightening torque values given in the above table serve only as a guide. A k factor of 0.2 has been used which assumes threads are plain finish, burr free with a light oil coating. It should be noted that these figures are based on the first tightening of single assemblies in isolation.

■ Metric Hex Bolts

HEX BOLTS - RECOMMENDED TIGHTENING TORQUE									
Class 10.9									
Size	Pitch (mm)	Stress Area (mm ²)	Core Area (mm ²)	Tensile Strength (kN)	Proof Strength (kN)	Shear Strength (kN)	Recommended Tightening Torque		
							Plain (Nm)	Zinc (Nm)	HDG (Nm)
M6	1.00	20.1	17.9	20.9	16.7	11.2	13.0	9.1	27.3
M8	1.25	36.6	32.8	38.1	30.4	20.5	31.6	22.1	66.3
M10	1.50	58.0	52.3	60.3	48.1	32.6	62.6	43.8	131.4
M12	1.75	84.3	76.2	87.7	70.0	47.5	109.2	76.4	229.2
M14	2.00	115.0	104.7	119.6	95.5	65.3	173.7	121.6	364.8
M16	2.00	157.0	144.0	163.3	130.3	89.9	271.0	189.7	569.2
M18	2.50	192.0	175.0	199.7	159.4	109.2	372.9	261.0	783.1
M20	2.50	245.0	225.0	254.8	203.3	140.4	528.7	370.1	1110.3
M22	2.50	303.0	281.0	315.1	251.5	175.3	719.3	503.5	1510.4
M24	3.00	353.0	324.0	367.1	293.0	202.2	914.1	639.9	1919.7
M27	3.00	459.0	427.0	477.4	381.0	266.4	1337.2	936.0	2808.1
M30	3.50	561.0	519.0	583.4	465.6	323.9	1816.0	1271.2	3813.5
M33	3.50	694.0	647.0	721.8	576.0	403.7	2471.1	1729.8	5189.4
M36	4.00	817.0	759.0	849.7	678.1	473.6	3173.6	2221.5	6664.5
M39	4.00	976.0	912.0	1015.0	810.1	569.1	4107.1	2875.0	8624.9
M42	4.50	1120.0	1050.0	1164.8	929.6	655.2	5075.6	3552.9	10658.8
M48	5.00	1470.0	1380.0	1528.8	1220.1	861.1	7613.4	5329.4	15988.2
M56	5.50	2030.0	1910.0	2111.2	1684.9	1191.8	12266.1	8586.3	25758.8
M64	6.00	2680.0	2520.0	2787.2	2224.4	1572.5	18507.0	12954.9	38864.7



***Not to be used for structural fasteners or structural applications.**

Note: The tightening torque values given in the above table serve only as a guide. A k factor of 0.2 has been used which assumes threads are plain finish, burr free with a light oil coating. It should be noted that these figures are based on the first tightening of single assemblies in isolation.

■ Metric Hex Bolts

HEX BOLTS - MINIMUM TENSILE STRESS (MPa or N / mm ²)						
Nominal Size	Pitch mm	Stress Area mm ²	Class 4.6	Class 8.8	AS1252	Class 10.9
M3	0.50	5.03	400	800	-	1040
M4	0.70	8.78	400	800	-	1040
M5	0.80	14.20	400	800	-	1040
M6	1.00	20.10	400	800	-	1040
M8	1.25	36.60	400	800	-	1040
M10	1.50	58.00	400	800	-	1040
M12	1.75	84.30	400	800	800	1040
M14	2.00	115.00	400	800	800	1040
M16	2.00	157.00	400	800	800	1040
M18	2.50	192.00	400	830	830	1040
M20	2.50	245.00	400	830	830	1040
M22	2.50	303.00	400	830	830	1040
M24	3.00	353.00	400	830	830	1040
M27	3.00	459.00	400	830	830	1040
M30	3.50	561.00	400	830	830	1040
M33	3.50	694.00	400	830	830	1040
M36	4.00	817.00	400	830	830	1040
M39	4.00	976.00	400	830	-	1040
M42	4.50	1121.00	400	830	-	1040
M48	5.00	1473.00	400	830	-	1040
M52	5.00	1758.00	400	830	-	1040
M64	6.00	2676.00	400	830	-	1040

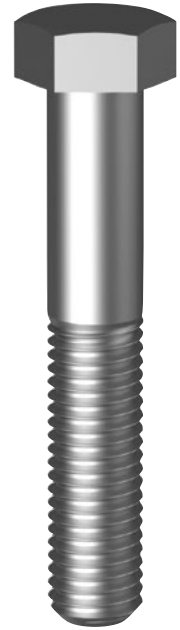

■ Metric Hex Bolts

HEX BOLTS - MINIMUM STRESS UNDER PROOF LOAD (MPa or N / mm ²)						
Nominal Size	Pitch mm	Stress Area mm ²	Class 4.6	Class 8.8	AS1252	Class 10.9
M3	0.50	5.03	225	580	-	830
M4	0.70	8.78	225	580	-	830
M5	0.80	14.20	225	580	-	830
M6	1.00	20.10	225	580	-	830
M8	1.25	36.60	225	580	-	830
M10	1.50	58.00	225	580	-	830
M12	1.75	84.30	225	580	580	830
M14	2.00	115.00	225	580	580	830
M16	2.00	157.00	225	580	580	830
M18	2.50	192.00	225	600	600	830
M20	2.50	245.00	225	600	600	830
M22	2.50	303.00	225	600	600	830
M24	3.00	353.00	225	600	600	830
M27	3.00	459.00	225	600	600	830
M30	3.50	561.00	225	600	600	830
M33	3.50	694.00	225	600	600	830
M36	4.00	817.00	225	600	600	830
M39	4.00	976.00	225	600	-	830
M42	4.50	1121.00	225	600	-	830
M48	5.00	1473.00	225	600	-	830
M52	5.00	1758.00	225	600	-	830
M64	6.00	2676.00	225	600	-	830

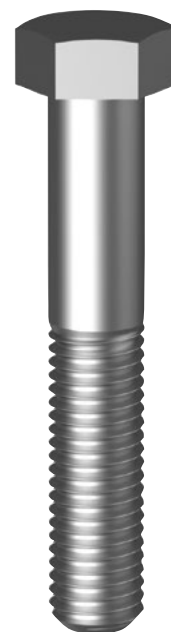

■ Metric Hex Bolts

HEX BOLTS - MINIMUM PROOF LOAD (KN)						
Nominal Size	Pitch mm	Stress Area mm ²	Class 4.6	Class 8.8	AS1252	Class 10.9
M3	0.50	5.03	1.13	2.92	-	4.17
M4	0.70	8.78	1.98	5.09	-	7.29
M5	0.80	14.20	3.20	8.24	-	11.79
M6	1.00	20.10	4.52	11.66	-	16.68
M8	1.25	36.60	8.24	21.23	-	30.38
M10	1.50	58.00	13.10	33.60	-	48.10
M12	1.75	84.30	19.00	48.90	48.90	70.00
M14	2.00	115.00	25.90	66.70	66.70	95.50
M16	2.00	157.00	35.30	91.10	91.10	130.30
M18	2.50	192.00	43.20	115.20	115.20	159.40
M20	2.50	245.00	55.10	147.00	147.00	203.30
M22	2.50	303.00	68.20	181.80	181.80	251.50
M24	3.00	353.00	79.40	211.80	211.80	293.00
M27	3.00	459.00	103.30	275.40	275.40	381.00
M30	3.50	561.00	126.20	336.60	336.60	465.60
M33	3.50	694.00	156.20	416.40	416.40	576.00
M36	4.00	817.00	183.80	490.20	490.20	678.10
M39	4.00	976.00	219.60	585.60	-	810.10
M42	4.50	1121.00	252.20	672.60	-	930.40
M48	5.00	1473.00	331.40	883.80	-	1222.60
M52	5.00	1758.00	395.60	1054.80	-	1459.10
M64	6.00	2676.00	602.10	1605.60	-	2221.10



■ Metric Hex Bolts

HEX BOLTS - MINIMUM ULTIMATE TENSILE LOAD (KN)						
Nominal Size	Pitch mm	Stress Area mm ²	Class 4.6	Class 8.8	AS1252	Class 10.9
M3	0.50	5.03	2.01	4.02	-	5.23
M4	0.70	8.78	3.51	7.02	-	9.13
M5	0.80	14.20	5.68	11.36	-	14.77
M6	1.00	20.10	8.04	16.08	-	20.90
M8	1.25	36.60	14.60	29.28	-	38.06
M10	1.50	58.00	23.20	46.40	-	60.30
M12	1.75	84.30	33.70	67.40	67.40	87.70
M14	2.00	115.00	46.00	92.00	92.00	119.60
M16	2.00	157.00	62.80	125.60	125.60	163.30
M18	2.50	192.00	76.80	159.40	159.40	199.70
M20	2.50	245.00	98.00	203.30	203.30	254.80
M22	2.50	303.00	121.20	251.50	251.50	315.10
M24	3.00	353.00	141.20	293.00	293.00	367.10
M27	3.00	459.00	183.60	381.00	381.00	477.40
M30	3.50	561.00	224.40	465.60	465.60	583.40
M33	3.50	694.00	277.60	576.00	576.00	721.80
M36	4.00	817.00	326.80	678.10	678.10	849.70
M39	4.00	976.00	390.40	810.10	-	1015.00
M42	4.50	1121.00	448.40	930.40	-	1165.80
M48	5.00	1473.00	589.20	1222.60	-	1531.90
M52	5.00	1758.00	703.20	1459.10	-	1828.30
M64	6.00	2676.00	1070.40	2221.10	-	2783.00



Imperial (UNC) Hex Bolts

UNC HEX BOLTS - MINIMUM STRESS UNDER PROOF LOAD (lbf/in ²)					
Nominal Size	TPI	Stress Area in ²	Grade 2	Grade 5	Grade 8
1/4"	20	0.0318	55,000	85,000	120,000
5/16"	18	0.0524	55,000	85,000	120,000
3/8"	16	0.0775	55,000	85,000	120,000
7/16"	14	0.1063	55,000	85,000	120,000
1/2"	13	0.1419	55,000	85,000	120,000
9/16"	12	0.182	55,000	85,000	120,000
5/8"	11	0.226	55,000	85,000	120,000
3/4"	10	0.334	55,000	85,000	120,000
7/8"	9	0.462	33,000	85,000	120,000
1"	8	0.606	33,000	85,000	120,000
1 1/8"	7	0.763	33,000	74,000	120,000
1 1/4"	7	0.969	33,000	74,000	120,000
1 3/8"	6	1.155	33,000	74,000	120,000
1 1/2"	6	1.405	33,000	74,000	120,000
1 3/4"	5	1.9	33,000	74,000	120,000
2"	4.5	2.5	33,000	74,000	120,000
2 1/4"	4.5	3.25	33,000	74,000	120,000

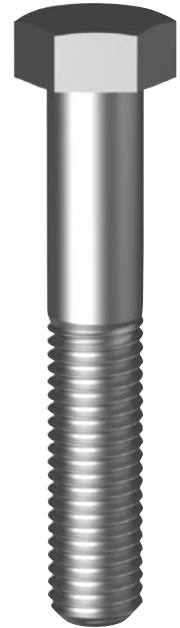

*Extrapolated

Imperial (UNC) Hex Bolts

UNC HEX BOLTS - MINIMUM TENSILE STRESS (lbf/in ²)					
Nominal Size	TPI	Stress Area in ²	Grade 2	Grade 5	Grade 8
1/4"	20	0.0318	74,000	120,000	150,000
5/16"	18	0.0524	74,000	120,000	150,000
3/8"	16	0.0775	74,000	120,000	150,000
7/16"	14	0.1063	74,000	120,000	150,000
1/2"	13	0.1419	74,000	120,000	150,000
9/16"	12	0.182	74,000	120,000	150,000
5/8"	11	0.226	74,000	120,000	150,000
3/4"	10	0.334	74,000	120,000	150,000
7/8"	9	0.462	60,000	120,000	150,000
1"	8	0.606	60,000	120,000	150,000
1 1/8"	7	0.763	60,000	105,000	150,000
1 1/4"	7	0.969	60,000	105,000	150,000
1 3/8"	6	1.155	60,000	105,000	150,000
1 1/2"	6	1.405	60,000	105,000	150,000
1 3/4"	5	1.9	60,000	105,000	150,000
2"	4.5	2.5	60,000	105,000	150,000
2 1/4"	4.5	3.25	60,000	105,000	150,000



*Extrapolated

Imperial (UNC) Hex Bolts

UNC HEX BOLTS - MINIMUM PROOF LOAD (lbf)					
Nominal Size	TPI	Stress Area in ²	Grade 2	Grade 5	Grade 8
1/4"	20	0.0318	1,749	2,703	3,816
5/16"	18	0.0524	2,882	4,454	6,288
3/8"	16	0.0775	4,263	6,588	9,300
7/16"	14	0.1063	5,847	9,036	12,756
1/2"	13	0.1419	7,805	12,062	17,028
9/16"	12	0.182	10,010	15,470	21,840
5/8"	11	0.226	12,430	19,210	27,120
3/4"	10	0.334	18,370	28,390	40,080
7/8"	9	0.462	15,246	39,270	55,440
1"	8	0.606	19,998	51,510	72,720
1 1/8"	7	0.763	25,179	56,462	91,560
1 1/4"	7	0.969	31,977	71,706	116,280
1 3/8"	6	1.155	38,115	85,470	138,600
1 1/2"	6	1.405	46,365	103,970	168,600
1 3/4"	5	1.9	62,700	140,600	228,000
2"	4.5	2.5	82,500	185,000	300,000
2 1/4"	4.5	3.25	107,250	240,500	390,000

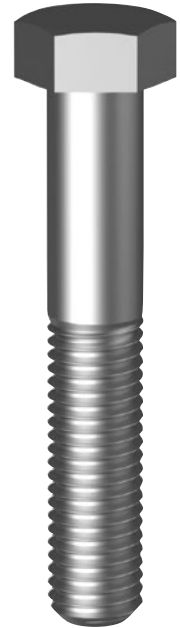

*Extrapolated

Imperial (UNC) Hex Bolts

UNC HEX BOLTS - MINIMUM TENSILE STRESS (lbf)					
Nominal Size	TPI	Stress Area in ²	Grade 2	Grade 5	Grade 8
1/4"	20	0.0318	2353	3,816	4,770
5/16"	18	0.0524	3,878	6,288	7,860
3/8"	16	0.0775	5,735	9,300	11,625
7/16"	14	0.1063	7,866	12,756	15,945
1/2"	13	0.1419	10,501	17,028	21,285
9/16"	12	0.182	13,468	21,840	27,300
5/8"	11	0.226	16,724	27,120	33,900
3/4"	10	0.334	24,716	40,080	50,100
7/8"	9	0.462	27,720	55,440	69,300
1"	8	0.606	36,360	72,720	90,900
1 1/8"	7	0.763	45,780	80,115	114,450
1 1/4"	7	0.969	58,140	101,745	145,350
1 3/8"	6	1.155	69,300	121,275	173,250
1 1/2"	6	1.405	84,300	147,525	210,750
1 3/4**	5	1.9	114,000	199,500	285,000
2**	4.5	2.5	150,000	262,500	375,000
2 1/4**	4.5	3.25	195,000	341,250	487,500



*Extrapolated

■ Metric Hex Nuts

HEX NUTS - STRESS UNDER PROOF LOAD (MPa OR N / mm ²)								
Nominal Size	Pitch mm	Stress Area mm ²	Class 5	Class 8	Class 10	Class 12**	AS1252	Mild Steel Hex Coupler
M3	0.50	5.03	520	800	1040	1140	-	520
M4	0.70	8.78	520	800	1040	1140	-	520
M5	0.80	14.20	580	855	1040	1140	-	580
M6	1.00	20.10	580	870	1040	1140	-	580
M8	1.25	36.60	590	870	1040	1140	-	590
M10	1.50	58.00	590	870	1050	1140	-	590
M12	1.75	84.30	610	880	1050	1170	1075	610
M14	2.00	115.00	610	880	1050	1170	-	610
M16	2.00	157.00	610	880	1050	1170	1075	610
M18	2.50	192.00	630	920	1060	1170	-	630
M20	2.50	245.00	630	920	1060	1170	1075	630
M22	2.50	303.00	630	920	1060	1170	1075	630
M24	3.00	353.00	630	920	1060	1170	1075	630
M27	3.00	459.00	630	920	1060	1170	1075	630
M30	3.50	561.00	630	920	1060	1170	1075	630
M33	3.50	694.00	630	920	1060	1170	1075	630
M36	4.00	817.00	630	920	1060	1170	1075	630
M39	4.00	976.00	630	920	1060	1170	-	630
M42*	4.50	1121.00	630	920	1060	1170	-	630
M48*	5.00	1473.00	630	920	1060	1170	-	630
M52*	5.00	1758.00	630	920	1060	1170	-	630
M64*	6.00	2676.00	630	920	1060	1170	-	630

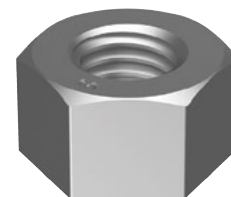

*Extrapolated. ** Extrapolated for >M16.

■ Metric Hex Nuts

HEX NUTS - MINIMUM PROOF LOAD (KN)								
Nominal Size	Pitch mm	Stress Area mm ²	Class 5	Class 8	Class 10	Class 12**	AS1252	Mild Steel Hex Coupler
M3	0.50	5.03	2.62	4.02	5.23	5.73	-	2.62
M4	0.70	8.78	4.57	7.02	9.13	10.01	-	4.57
M5	0.80	14.20	8.24	12.14	14.77	16.19	-	8.24
M6	1.00	20.10	11.66	17.49	20.90	22.91	-	11.66
M8	1.25	36.60	21.59	31.84	38.06	41.72	-	21.59
M10	1.50	58.00	34.22	50.46	60.90	66.12	-	34.22
M12	1.75	84.30	51.42	74.18	88.52	98.63	90.62	51.42
M14	2.00	115.00	70.15	101.20	120.75	134.55	-	70.15
M16	2.00	157.00	95.77	138.16	164.85	183.69	168.78	95.77
M18	2.50	192.00	120.96	176.64	203.52	224.64	-	120.96
M20	2.50	245.00	154.35	225.40	259.70	286.65	263.38	154.35
M22	2.50	303.00	190.89	278.76	321.18	354.51	325.73	190.89
M24	3.00	353.00	222.39	324.76	374.18	413.01	379.48	222.39
M27	3.00	459.00	289.17	422.28	486.54	537.03	493.43	289.17
M30	3.50	561.00	353.43	516.12	594.66	656.37	603.08	353.43
M33	3.50	694.00	437.22	638.48	735.64	811.98	746.05	437.22
M36	4.00	817.00	514.71	751.64	866.02	955.89	878.28	514.71
M39	4.00	976.00	614.88	897.92	1034.56	1141.92	-	614.88
M42*	4.50	1121.00	706.23	1031.32	1188.26	1311.57	-	706.23
M48*	5.00	1473.00	927.99	1355.16	1561.38	1723.41	-	927.99
M52*	5.00	1758.00	1107.54	1617.36	1863.48	2056.86	-	1107.54
M64*	6.00	2676.00	1685.88	2461.92	2836.56	3130.92	-	1685.88

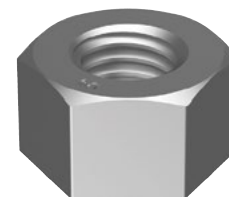

*Extrapolated. ** Extrapolated for >M16.

BREAKING STRENGTH COMPARISON

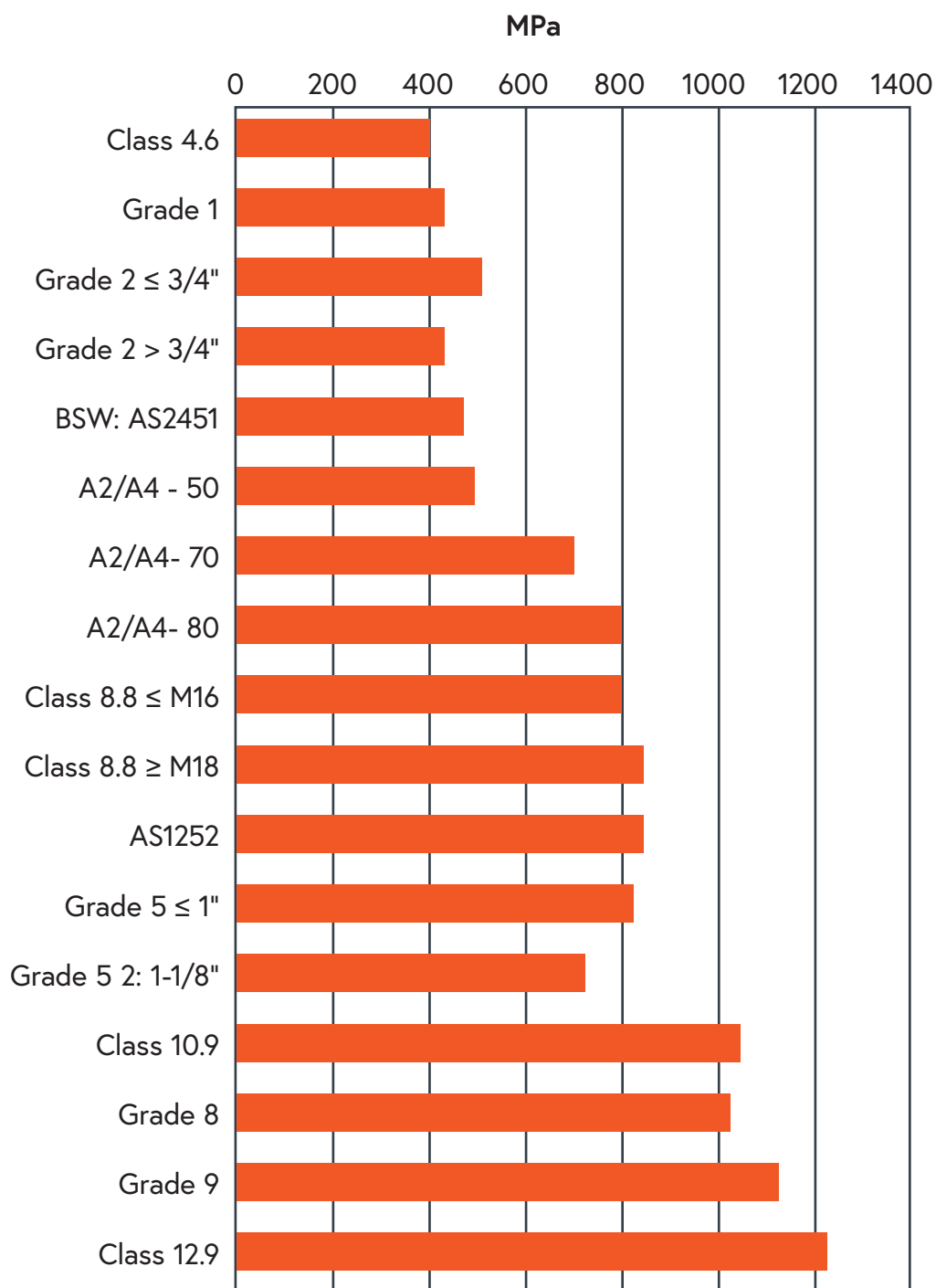



sales@fdgnz.com

20 Mansel Dr, Warkworth, Auckland 0910 New Zealand

09-275-6811